

Evergreen 200 22 Modules
1 string of 22 in series

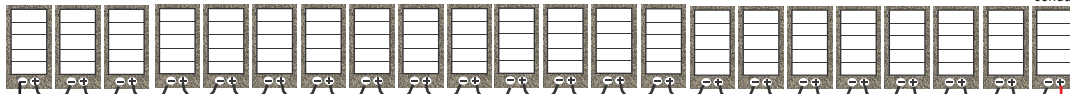

3/4" EMT Conduit with two #8 AWG, THWN conductors, a #8 AWG, THWN equipment grounding conductor and a #8 AWG, THWN DC circuit grounding conductor (for all conduit from Inverter to Main Service Panel)

8 GA THHN

3/4" EMT Conduit with two #12 AWG, THWN conductors and a #12 AWG, THWN equipment grounding conductor (for all conduit from rooftop combiner to PV Power Source Disconnect)

12 GA THHN

SB4000US
DC/AC Inverter
(notes 4, 5, 6)

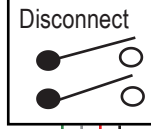
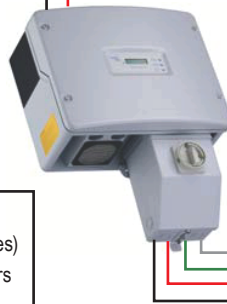

8 GA THHN

Export
Meter

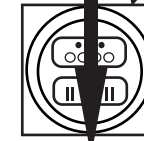

Company
owned
service

Outdoor
Indoor

Notes:

1. PV Array contains two parallel strings of 12, 220 Watt Modules in series (24-modules)
2. PV Array wiring to combiner is #10 AWG THHN with factory-installed MC connectors to interface with modules
3. PV Power Source Disconnect
4. Ground-Fault Protection provided in DC/AC Inverter
5. DC/AC Inverter is SB4000US model rated at 4 kW AC output and is rated to provide 17 amps at 240 Volts at 40°C
6. Inverter is Listed to UL-1741 "Utility-Interactive"
7. Utility Switch is visible open, lockable in open position, 240-Vac, 30-amp switch
8. 200 Amp Main Service Panel with 30 amp Two-Pole Circuit Breaker for Interactive Point of Connection (up to 40 amp allowed for 200 amp busbar—NEC 690.64(B)(2) exception)
9. Equipment grounding conductors on AC- and DC-side sized according to NEC 250.122
10. Negative pole of PV array referenced to ground at the Inverter
11. All grounds connected to main service ground in Main Service Panel
12. General Notes - this design is not intended to be a complete design and is only for reference. All installations should meet national and local codes. Contact local licensed professionals to ensure installation meets all applicable codes.

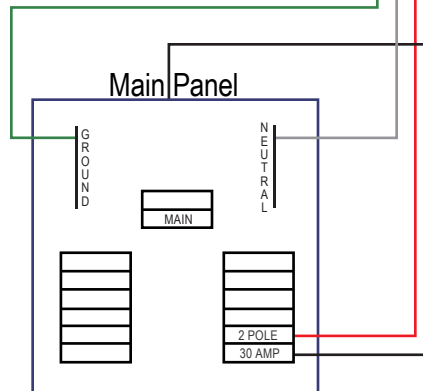

Operating Voltage	240
Operating Current	17
Maximum System Voltage	507
Short Circuit Current	18

Revision #:	Scale:	Solar System Plan:	Solar System Design by: Leon Bontrager
Date: 5/3/10	None	4.4 KW Kyocera PV System	Home Energy LLC